



# Area-scan cameras



Area-scan cameras are grayscale and color cameras utilizing the GigE Vision standard. Thanks to their small housing, the cameras allow for easy installation in locations where space is constrained. The cameras are the ideal solution for fast embedded vision system integration and ensures an outstanding price/performance ratio. High resolution and frame rate guarantee superior image acquisition for tackling most complex machine vision applications.

- VGA to 24.4MP resolution, in both grayscale and color
- CMOS image sensors for high speed performance
- Power over Ethernet (PoE) guarantees minimum wiring and easy installation
- Compact housing (as small as 29 x 29 x 60 mm) enables mounting in space-constrained locations
- High Frame rates to keep up with high speed inspections
- Trigger and strobe I/O provide outstanding integration flexibility



## TECHNICAL SPECIFICATIONS

	Camera M1**	Camera E1**	Camera E2-***
<b>COMMUNICATION</b>			
PoE		Yes	
Camera Interface		GigE	
<b>ELECTRICAL DATA</b>			
Supply voltage	12 Vdc or PoE		12 ... 24 Vdc or PoE
<b>MECHANICAL DATA</b>			
Lens mount		C-Mount	
<b>ENVIRONMENTAL DATA</b>			
Operating Temperature		-10 ... 50 °C	
Mechanical Protection		IP30	

# Area-scan cameras AVAILABLE MODELS

CAMERAS

Resolution	Mono / Color	Lens mount	Frame rate (FPS)	Model
659 x 480 pixels	Color	C-Mount	300 fps	<b>CAM-E101C-0.3-C-300-G-G</b> (959933023)
	Monochrome			<b>CAM-E101-0.3-M-300-G-G</b> (959933022)
1280 x 1024 pixels	Color		75 fps	<b>CAM-E151C-1.3-C-75-G-G</b> (959933025)
	Monochrome			<b>CAM-E151-1.3-M-75-G-G</b> (959933024)
1600 x 1200 pixels	Color		60 fps	<b>CAM-E182C-2.3-C-60-G-G</b> (959933039)
	Monochrome			<b>CAM-E182-2.3-M-60-G-G</b> (959933038)
1920 x 1200 pixels	Color		48 fps	<b>CAM-E181C-2-C-48-G-G</b> (959933027)
	Monochrome			<b>CAM-E181-2-M-48-G-G</b> (959933026)
2048 x 1088 pixels	Color		60 fps	<b>CAM-M190C-2.3-C-50-G-G</b> (601-0455)
	Monochrome		50 fps	<b>CAM-M190-2.3-M-50-G-G</b> (601-0454)
2048 x 1536 pixels	Color		35 fps	<b>CAM-E193C-5-C-35-G-G</b> (959933043)
	Monochrome			<b>CAM-E193-5-M-35-G-G</b> (959933042)
2048 x 2048 pixels	Color		25 fps	<b>CAM-M195C-4-C-25-G-G</b> (601-0457)
	Monochrome			<b>CAM-M195-4-M-25-G-G</b> (601-0456)
2448 x 2048 pixels	Color		20 fps	<b>CAM-E198C-5-C-20-G-G</b> (959933045)
	Monochrome			<b>CAM-E198-5-M-20-G-G</b> (959933044)
2592 x 1944 pixels	Color		14 fps	<b>CAM-M197C-5-C-14-G-G</b> (959931011)
	Monochrome			<b>CAM-M197-5-M-14-G-G</b> (959931010)
4096 x 3000 pixels	Color		9 fps	<b>CAM-E2-12.3-C-9-G-G</b> (959980012)
	Monochrome			<b>CAM-E2-12.3-M-9-G-G</b> (959980011)
5328 x 4608 pixels	Color	4 fps	<b>CAM-E2-24.4-C-4-G-G</b> (959980014)	
	Monochrome		<b>CAM-E2-24.4-M-4-G-G</b> (959980013)	

# CONNECTIONS

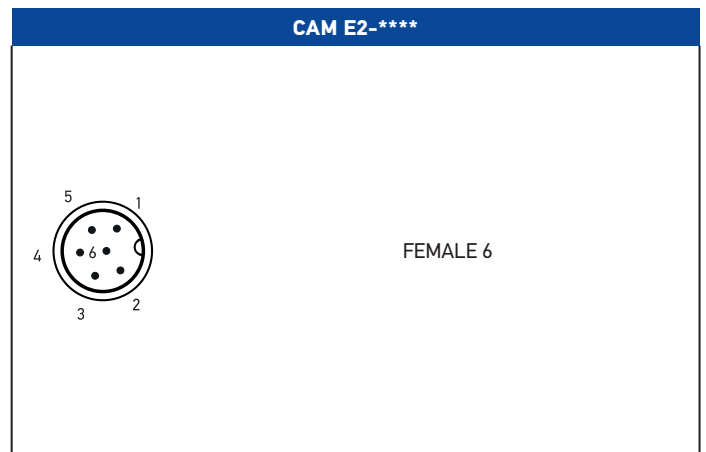
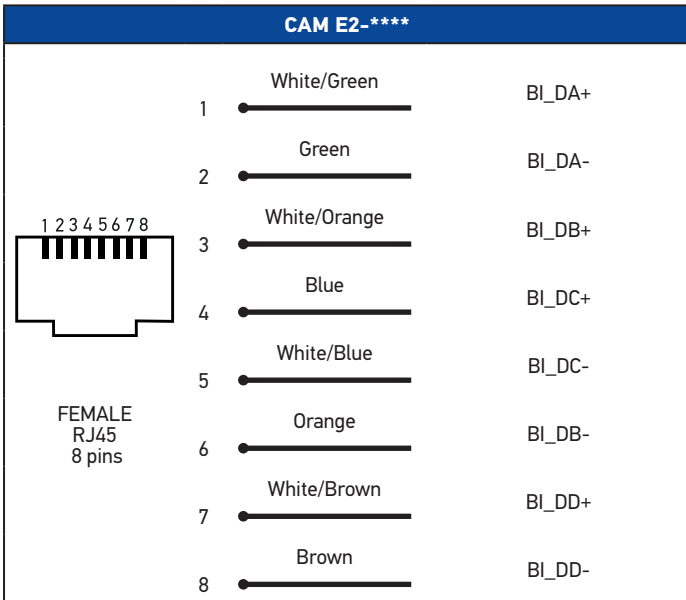
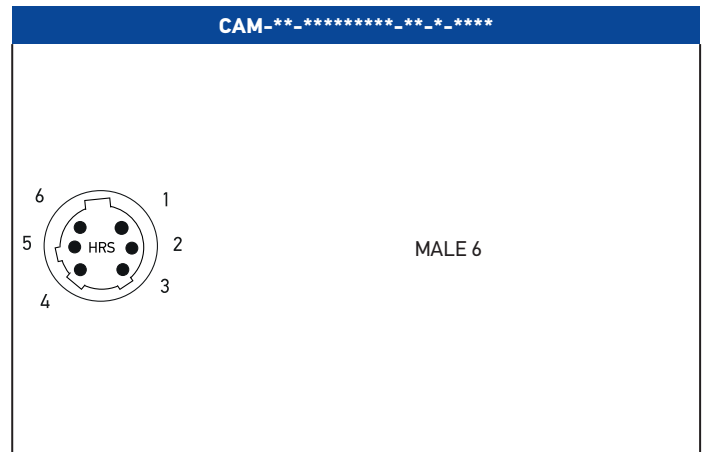
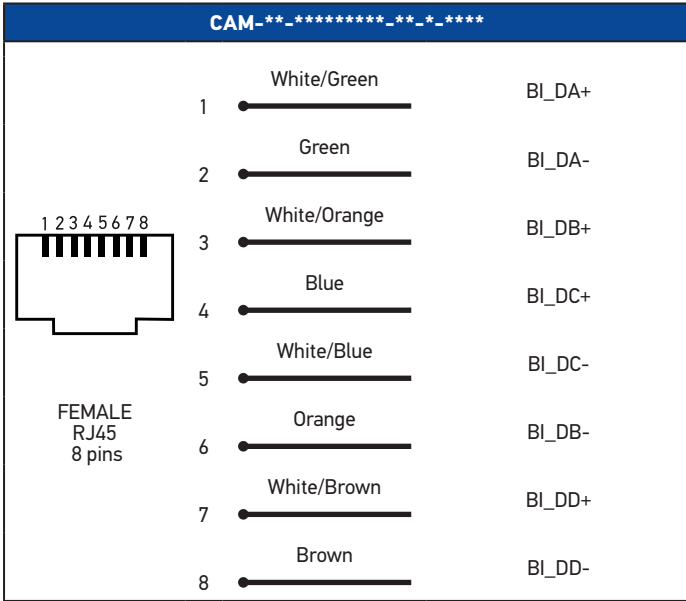

CAM\_\*\*\*\*

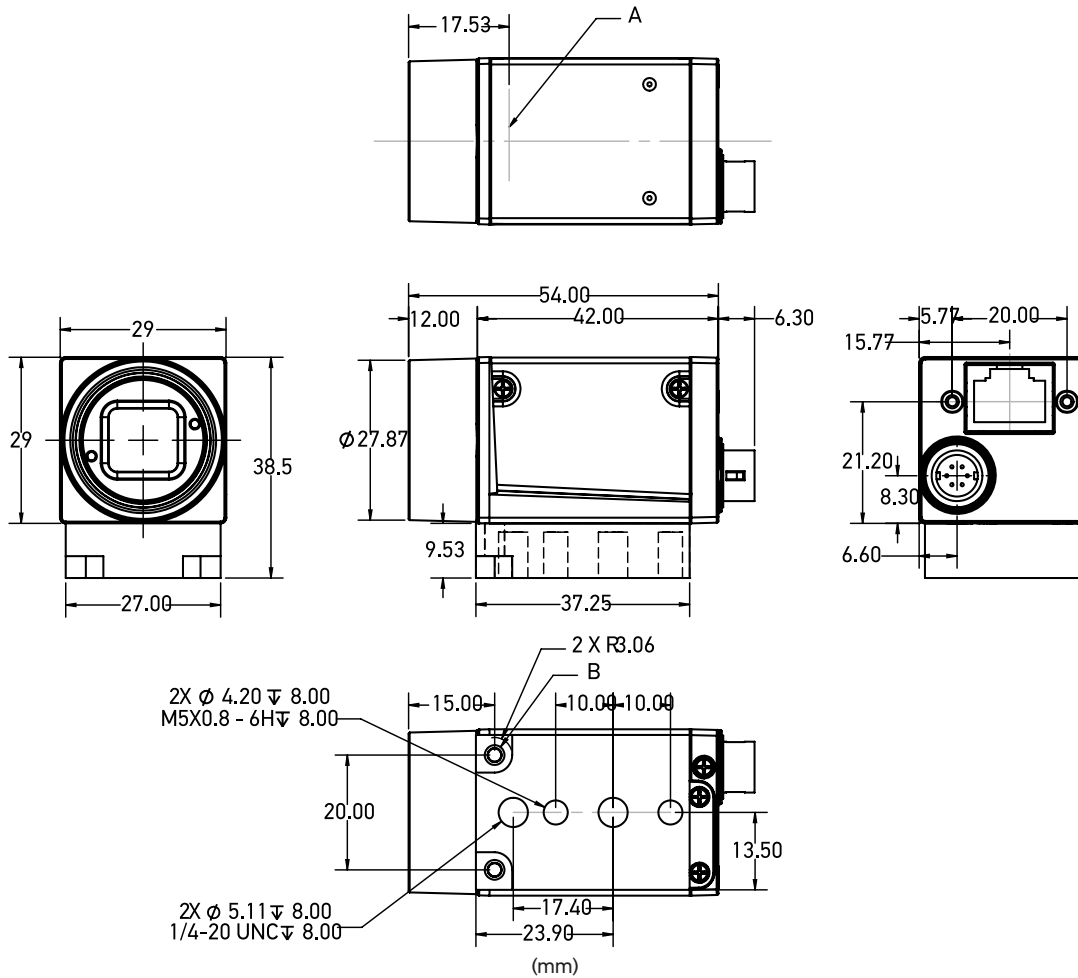

A

B

CAM-M1\*\*

Photosensitive surface of the sensor

2 x  $\varnothing 3.45$  thru all

CAM E2-\*\*\*\*

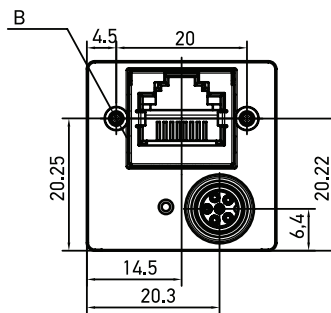
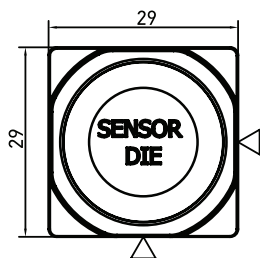
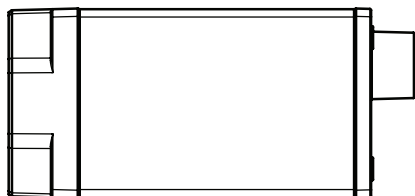
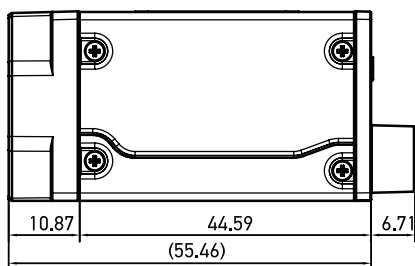
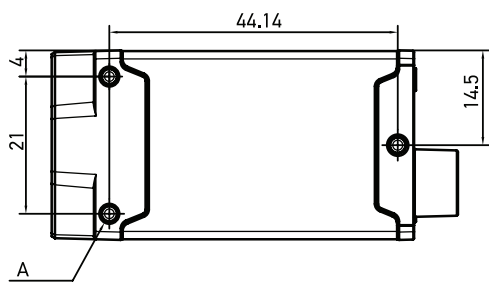

(mm)

Models	A	B
CAM E2-****	3x M3; 4 deep	2x M2; 4 deep

# ACCESSORIES TO BE ORDERED SEPARATELY

	Model	Description	Article code
<b>Cables</b>	CAB-IO-6P-3-PT	Cable, M1xx, M5xx and E1xx Camera, I/O, 6 pin, 3 Meter, pigtail	606-0672-03
	CAB-IO-6P-5-PT	Cable, M1xx, M5xx and E1xx Camera, I/O, 6 pin, 5 Meter, pigtail	606-0672-05
	CAB-IO-6P-10-PT	Cable, M1xx, M5xx and E1xx Camera, I/O, 6 pin, 10 Meter, pigtail	606-0672-10
	CAB-IO-6P-3-TB	Cable, M1xx, M5xx and E1xx Camera, I/O, 6 pin, 3 Meter, Camera to Terminal Block	606-0674-03
	CAB-IO-6P-5-TB	Cable, M1xx, M5xx and E1xx Camera, I/O, 6 pin, 5 Meter, Camera to Terminal Block	606-0674-05
	CAB-IO-6P-10-TB	Cable, M1xx, M5xx and E1xx Camera, I/O, 6 pin, 10 Meter, Camera to Terminal Block	606-0674-10
	CAB-IO-6P-3-M8-DB9	Cable, I/O, E2 Camera, 6 pin, 3 Meter, M8 Camera Connector to DB9 Terminal Block	959930001
	CAB-IO-6P-5-M8-DB9	Cable, I/O, E2 Camera, 6 pin, 5 Meter, M8 Camera Connector to DB9 Terminal Block	959930002
	CAB-IO-6P-10-M8-DB9	Cable, I/O, E2 Camera, 6 pin, 10 Meter, M8 Camera Connector to DB9 Terminal Block	959930003
	CAB-GE-C6-03	Cable, Gig-E, CAT6, 3 Meter	606-0677-03
	CAB-GE-C6-05	Cable, Gig-E, CAT6, 5 Meter	606-0677-05
	CAB-GE-C6-10	Cable, Gig-E, CAT6, 10 Meter	606-0677-10
	CAB-GE-C5-03	Cable, Gig-E, Hi-Flex CAT-5e, 3 Meter	606-0677-HF-03
	CAB-GE-C5-05	Cable, Gig-E, Hi-Flex CAT-5e, 5 Meter	606-0677-HF-05
	CAB-GE-C5-10	Cable, Gig-E, Hi-Flex CAT-5e, 10 Meter	606-0677-HF-10
	CAB-GE-C6-HM-03	Cable, Gig-E, CAT6, Horizontal Mold, 3 Meter	606-0677-M1-03
	CAB-GE-C6-HM-05	Cable, Gig-E, CAT6, Horizontal Mold, 5 Meter	606-0677-M1-05
	CAB-GE-C6-HM-10	Cable, Gig-E, CAT6, Horizontal Mold, 10 Meter	606-0677-M1-10
	CAB-GE-C5-HM-03	Cable, Gig-E, Hi-Flex CAT-5e, Horizontal Mold, 3 Meter	606-0677-M1-HF-03
	CAB-GE-C5-HM-05	Cable, Gig-E, Hi-Flex CAT-5e, Horizontal Mold, 5 Meter	606-0677-M1-HF-05
CAB-GE-C5-HM-10	Cable, Gig-E, Hi-Flex CAT-5e, Horizontal Mold, 10 Meter	606-0677-M1-HF-10	
<b>I/O board</b>	IOB-M1/E1/E2-DIN	I/O Board, M1xx, E1xx and E2-xxx Camera, w / isolation	661-0399
<b>Lenses</b>	LEN-KOW-LM50XC	Lens, Kowa, 50mm, C-Mount, 4/3" Format, M37.5 x 0.5 filter thread, LM50CX	95A900091
	LEN-KOW-LM12XC	Lens, Kowa, 12mm, C-Mount, 4/3" Format, M55 x 0.75 filter thread, LM12CX	95A900087
	LEN-KOW-LM16XC	Lens, Kowa, 16mm, C-Mount, 4/3" Format, M40.5 x 0.5 filter thread, LM16CX	95A900088
	LEN-KOW-LM25XC	Lens, Kowa, 25mm, C-Mount, 4/3" Format, M40.5 x 0.5 filter thread, LM25CX	95A900089
	LEN-KOW-LM35XC	Lens, Kowa, 35mm, C-Mount, 4/3" Format, M37.5 x 0.5 filter thread, LM35CX	95A900090
<b>Mounting brackets</b>	CM-M1-E1	Camera Mount, M1xx and E1xx Cameras	381-1355
	CAM-ACC-MOUNT-E2	Camera Mount, E2-xxx Cameras	959930004
	CM-M1-E1-U1	Camera Mount, M1xx and E1xx Cameras Small	95A903029